

METAL CONTAINERS

- 4 WHEELS

1100 Litres

1100 L

Capacity

440 KG

Nominal load

200 mm

Wheels diameter



TECHNICAL SPECIFICATIONS

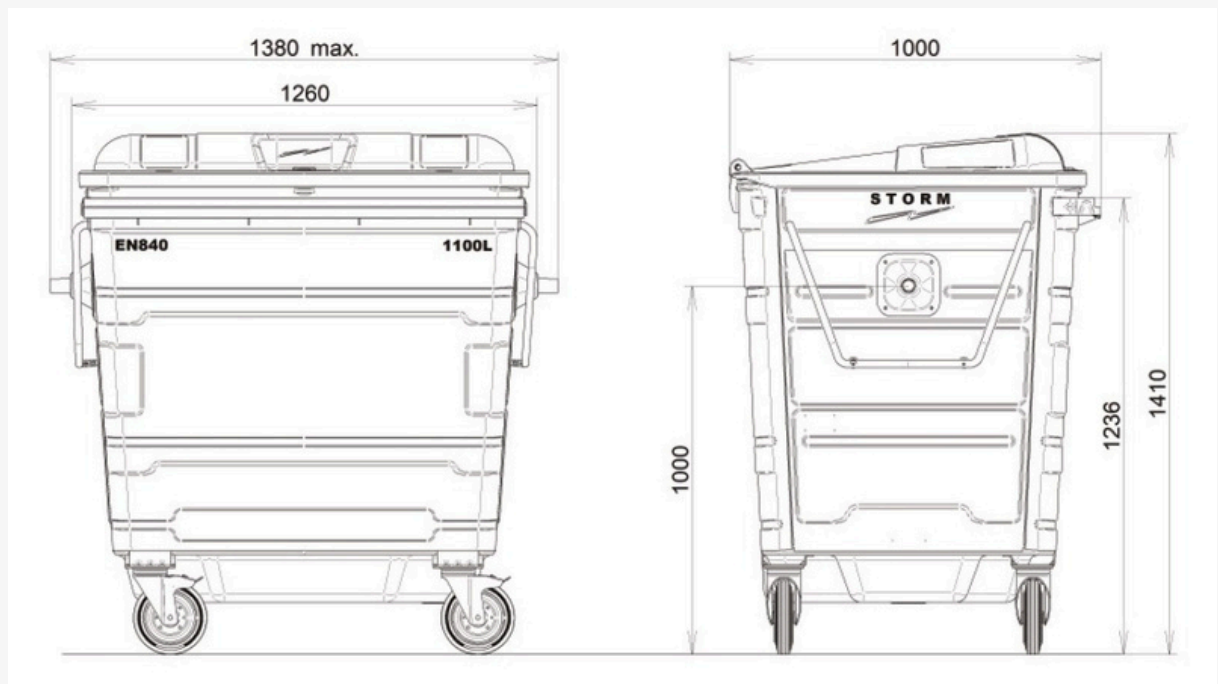

REAR LOADING CONTAINERS – 4 WHEELS

1100

FEATURES

- Designed for the storage and collection of dry mixed recyclables.
- The bin features heavy steel fabrication to protect the viewing windows, which are made of strong polycarbonate plastic.
- Transparent Sides leaves you in no doubt about which waste stream is inside.
- The clear-view panels have a triple purpose; first and foremost, they allow you to effortlessly gauge the bin's capacity, and secondly, they allow collection crews to quickly identify what is inside.

EQUIPMENT AND ACCESSORIES

- Front operating Brakes.
- Danish side handles fitted to aid with moving
- Galvanised steel construction.
- All seams are internally welded preventing any water ingress and increasing longevity in situ.
- Tow fittings
- RFID tagging

STANDARDS

- EN840 Compliant