

REAR LOADING CONTAINERS – 4 WHEELS

1280 Litres

1280 L

Capacity

440 KG

Nominal load

200 mm

Wheels diameter



TECHNICAL SPECIFICATIONS

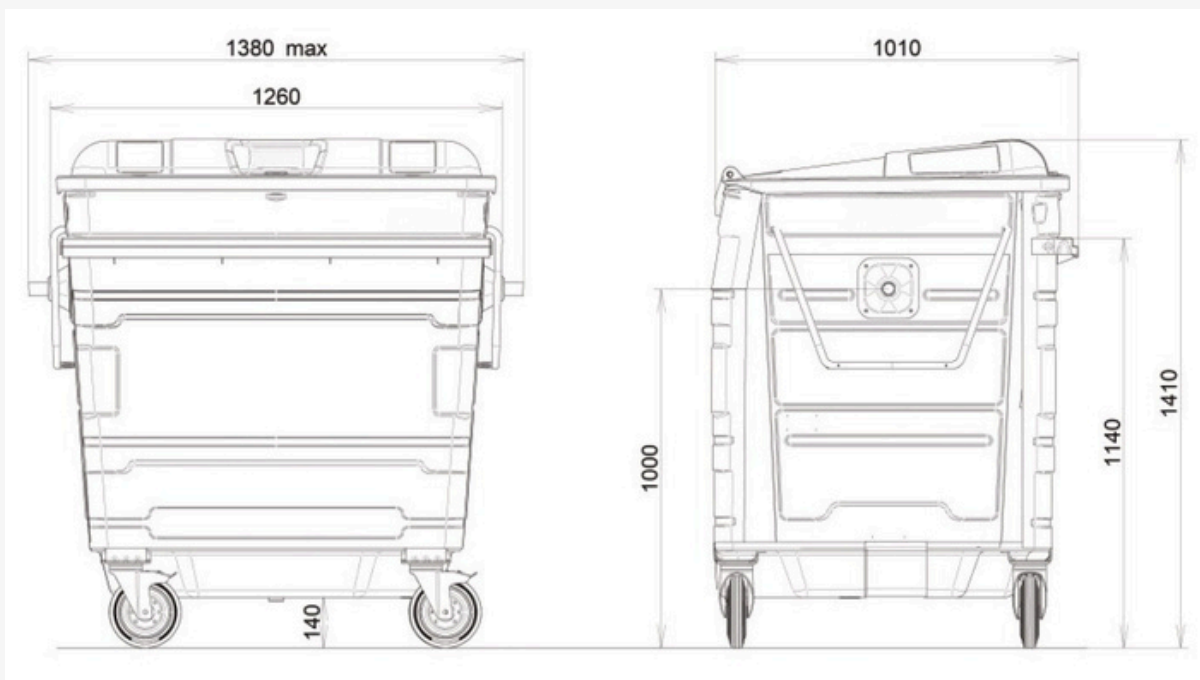

REAR LOADING CONTAINERS – 4 WHEELS

1280

FEATURES

- Manufactured and tested to EN840 (EN840 is the Europe-wide standard for emptying interoperability and handling safety).
- Danish handles are fitted as standard which offers improved manoeuvrability and health and safety benefits.
- Comb edge which is compatible with all standard lifting equipment.
- Fitted with a drain plug as standard to get rid of any liquid and to make cleaning a lot easier.
- 200mm swivel and brake castors as standard.
- Available with a range of options including recycling lids, heavy duty vinyl graphics for recycling or your logo
- Fire proof body
- Load capacity 440kg

EQUIPMENT AND ACCESSORIES

- Powder coated body & lid.
- The strong galvanized steel will also contain any waste fires by starving them of oxygen, quickly extinguishing the fire before it spreads further.

STANDARDS

- Manufactured and tested to EN840 (EN840 is the Europe-wide standard for emptying interoperability and handling safety).

