

METAL CONTAINERS

- 4 WHEELS

660 Litres

660 L

Capacity

265KG

Nominal load

200 mm

Wheels diameter



TECHNICAL SPECIFICATIONS

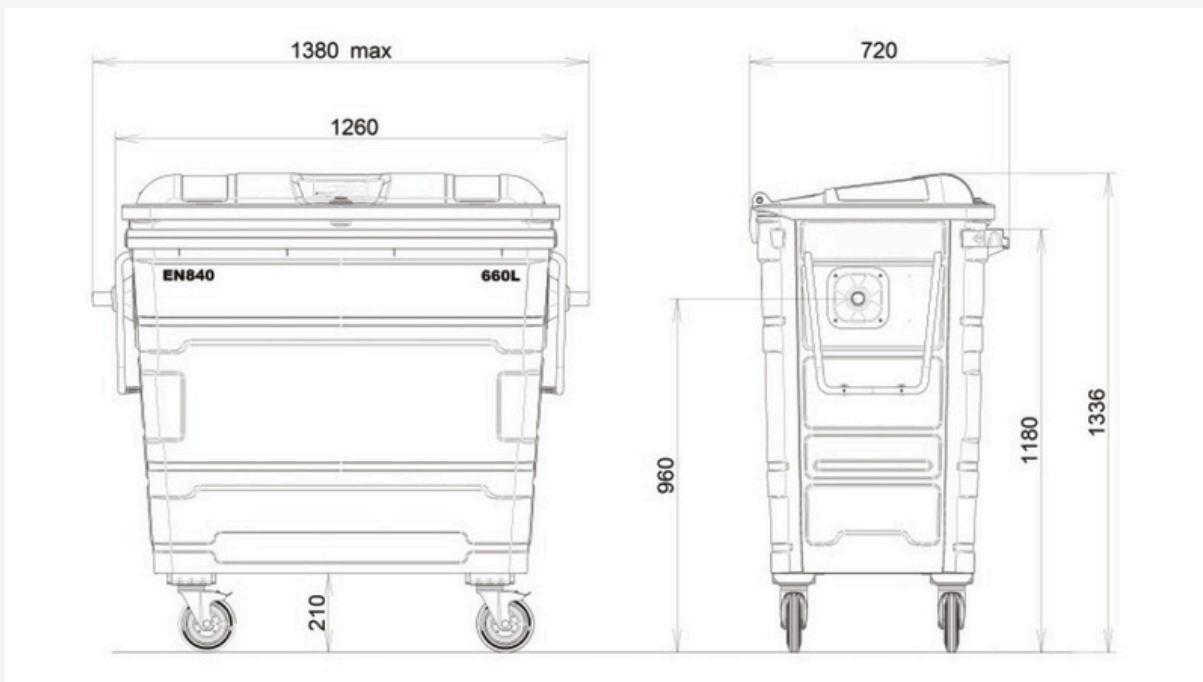

REAR LOADING CONTAINERS – 4 WHEELS

660

FEATURES

- Designed to reduce contamination in dry mixed recycling, and therefore reducing the amount of waste that ends up in landfill.
- Available in a galvanised or powder-coated finish, these wheelie bins are built to last and can handle up to 10 standard 65L refuse sacks.
- The 1.5mm thick steel panels provide exceptional strength and longevity, while internal seam welding keeps your bin watertight.
- Available with a range of options including recycling lids, heavy duty vinyl graphics for recycling or your logo

EQUIPMENT AND ACCESSORIES

- Tow fittings
- Restrictor plates
- Lid lock
- RFID tagging
- Din lifting points
- Fitted with a drain plug as standard to get rid of any liquid and to make cleaning a lot easier.
-

STANDARDS

- EN840, BS 9001:2015 & BS 14001 Compliant

