

REAR LOADING CONTAINERS – 4 WHEELS

770 Litres

770 L

Capacity

310 KG

Nominal load

200 mm

Wheels diameter



TECHNICAL SPECIFICATIONS

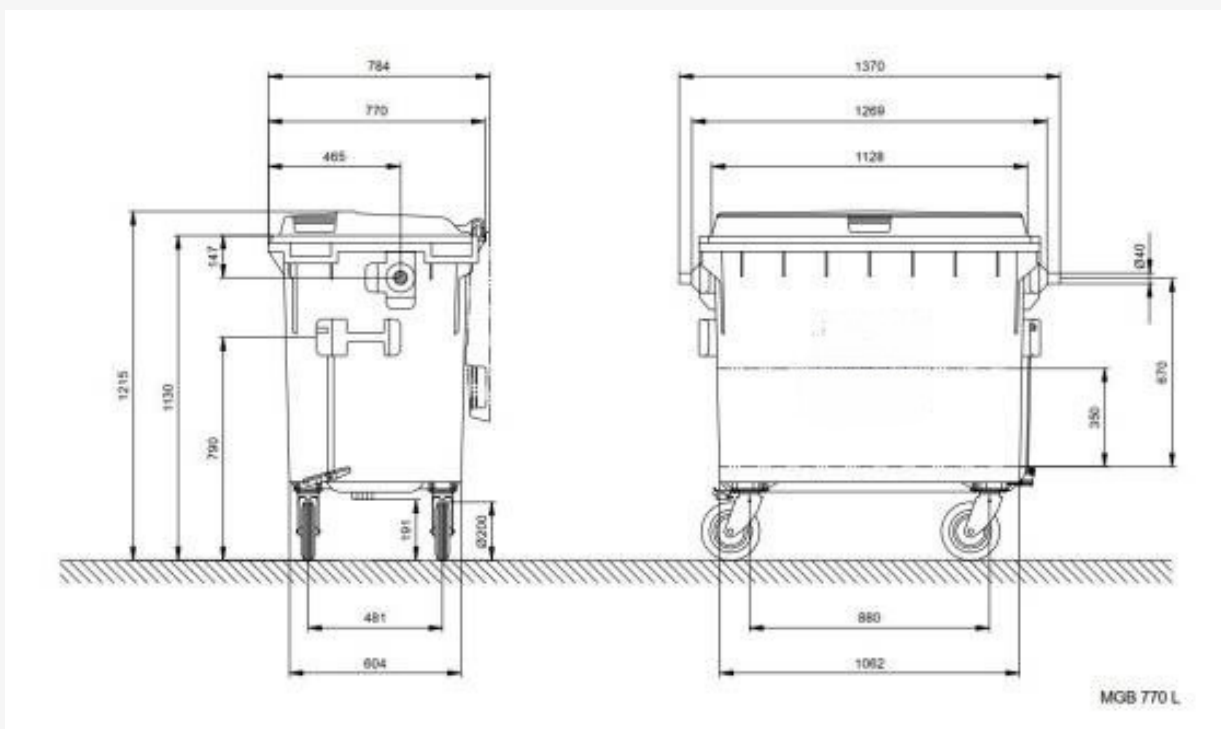

REAR LOADING CONTAINERS – 4 WHEELS

770**FEATURES**

- Manufactured by compact injection moulding process from high molecular weight, high-density polyethylene (HDPE) in accordance with the test regulations of DIN EN 840 and RAL GZ 951/1
- Resistant to frost, heat and chemicals; stabilised against UV radiation
- Standard emptying options of either DIN or comb-lifting device; optionally with Ochsner handles of zinc-plated steel
- Wheel stop brake system (dual stop) as standard feature; alternatively available with central braking system
- Zinc-plated, corrosion-resistant metal parts
- Optimised for high stacking with strong stacking ribs, thus saving space for storage and transportation
- Available colours: grey, blue, brown and green, additional colours upon request

EQUIPMENT AND ACCESSORIES

- Quiet-running, full rubber heavy-duty castors of 200 mm diameter, 360° swivel range
- A drain plug in the bottom facilitates cleaning

STANDARDS

- Conforms to requirements of directive 2000/14/EC. The mobile garbage bins are marked with the CE symbol and appropriate decibel level.
- The frontal comb is equipped with a chipnest to accommodate data carriers in accordance with DIN 30745 and RAL GZ 951/1.

