

REAR LOADING CONTAINERS – 2 WHEELS

Confidential Wheelie Bin

80-1100 L Available

Capacity

Size Dependant

Nominal load

200 mm

Wheels diameter



TECHNICAL SPECIFICATIONS

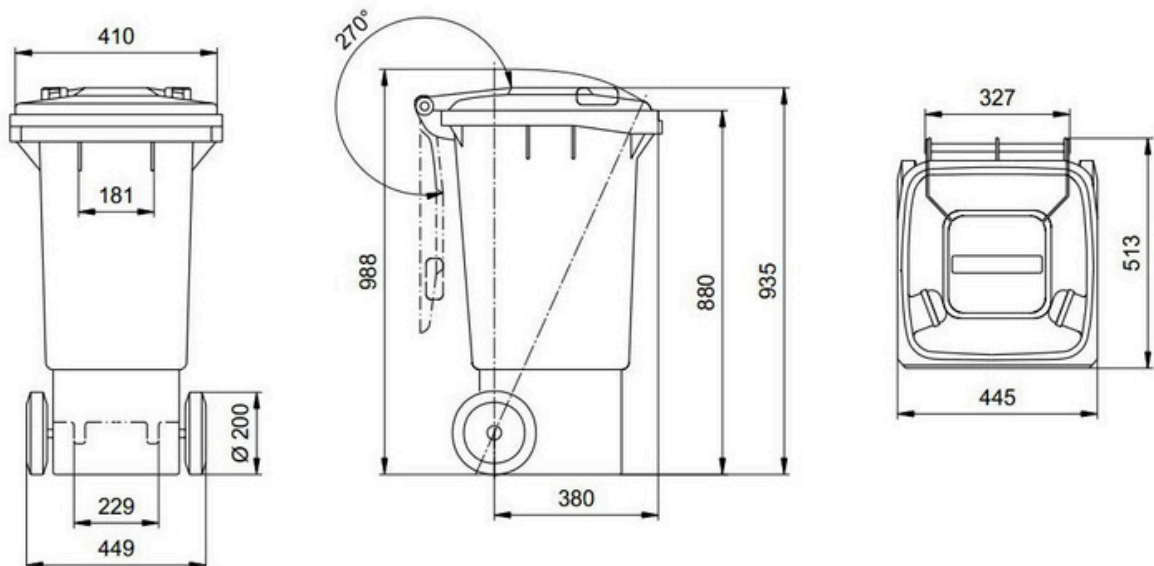

MGB 80 L

REAR LOADING CONTAINERS – 2 WHEELS

80 - 1100

FEATURES

- These secure and lockable bins keep all confidential waste safely contained until it is ready for shredding and disposal.
- Optional paper slot and lock mechanism allow access to authorised employees only and ensure documents can be disposed of easily.
- Medical documents, financial records or sensitive client information, our Confidential Wheelie Bin meets the strictest privacy and security requirements.
- Compliance with EN840 ensures these bins are safe to handle and compatible with all UK refuse vehicles.
- Easy to manoeuvre thanks to their durable wheels and axle.

EQUIPMENT AND ACCESSORIES

- Stepped comb-lift, reinforced with ribs, for maximum safety when emptying the waste recycling bins.
- Fitted with 200 mm diameter solid, quiet-running rubber wheels.
- Triangular Lock

STANDARDS

- Complies with the noise control regulation in accordance with EC directive 2000/14/EC and is marked with the appropriate noise level
- Manufactured in accordance with DIN EN 840 and RAL GZ 951/1

