

REAR LOADING CONTAINERS - 4 WHEELS

1100 Litres

1100 L
Capacity

440 Kg
Nominal load

200 mm
Wheels diameter



TECHNICAL SPECIFICATIONS

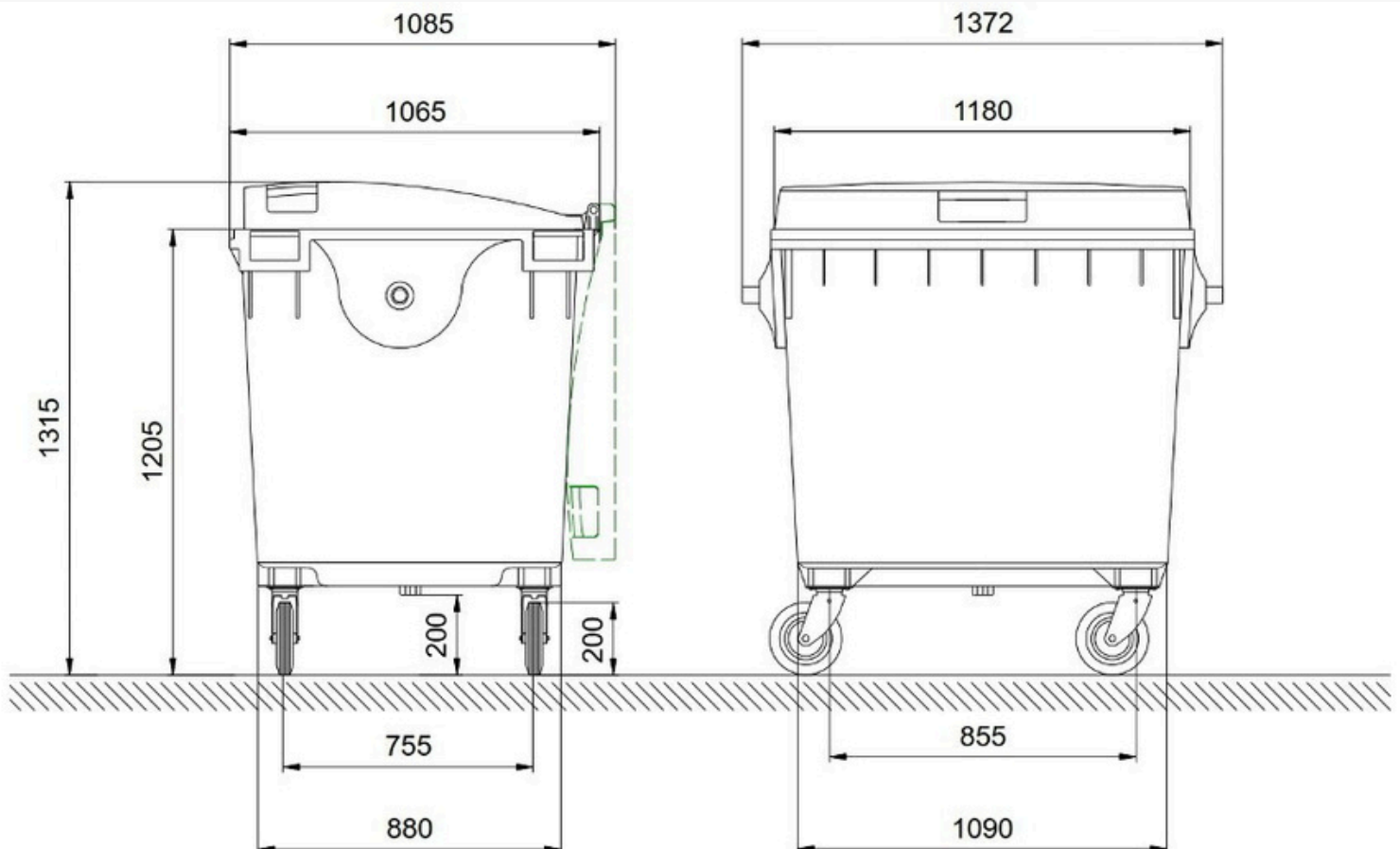

REAR LOADING CONTAINERS – 4 WHEELS

1100

FEATURES

- Designed with versatility in mind, these wheelie bins can accommodate various waste streams, including general waste, recyclables, and organic materials. They adhere to the stringent standards of EN840, guaranteeing quality and compliance. Explore the customization options available to tailor these bins to your specific requirements. If you seek enhanced durability, don't miss our selection of Metal 1100 Litre Wheelie Bins.
- Extremely weather-resistant and UV light-stabilised.
- Water run-off incl. water drainage spout as standard equipment.
- All metal parts are zinc-plated and therefore corrosion-resistant.

EQUIPMENT AND ACCESSORIES

- Available to purchase with: lock (not available with drop front door).
- Drop Front Door.
- Tow Kit.
- Fork Pockets.

STANDARDS

- Manufactured and tested to EN840 (EN840 is the Europe wide standard for emptying interoperability and handling safety).
- Actual empty weight - 50kg.
- Available in a Flat or Roll top lid.
- Flat Top: 1325mm x 1370mm x 1077mm (H x W x D)
- Roll Top: - 1463 mm x 1370 mm x 1077 mm (H x W x D)

